

# 3500 H-20 2 COMPARTMENT SEPTIC TANK

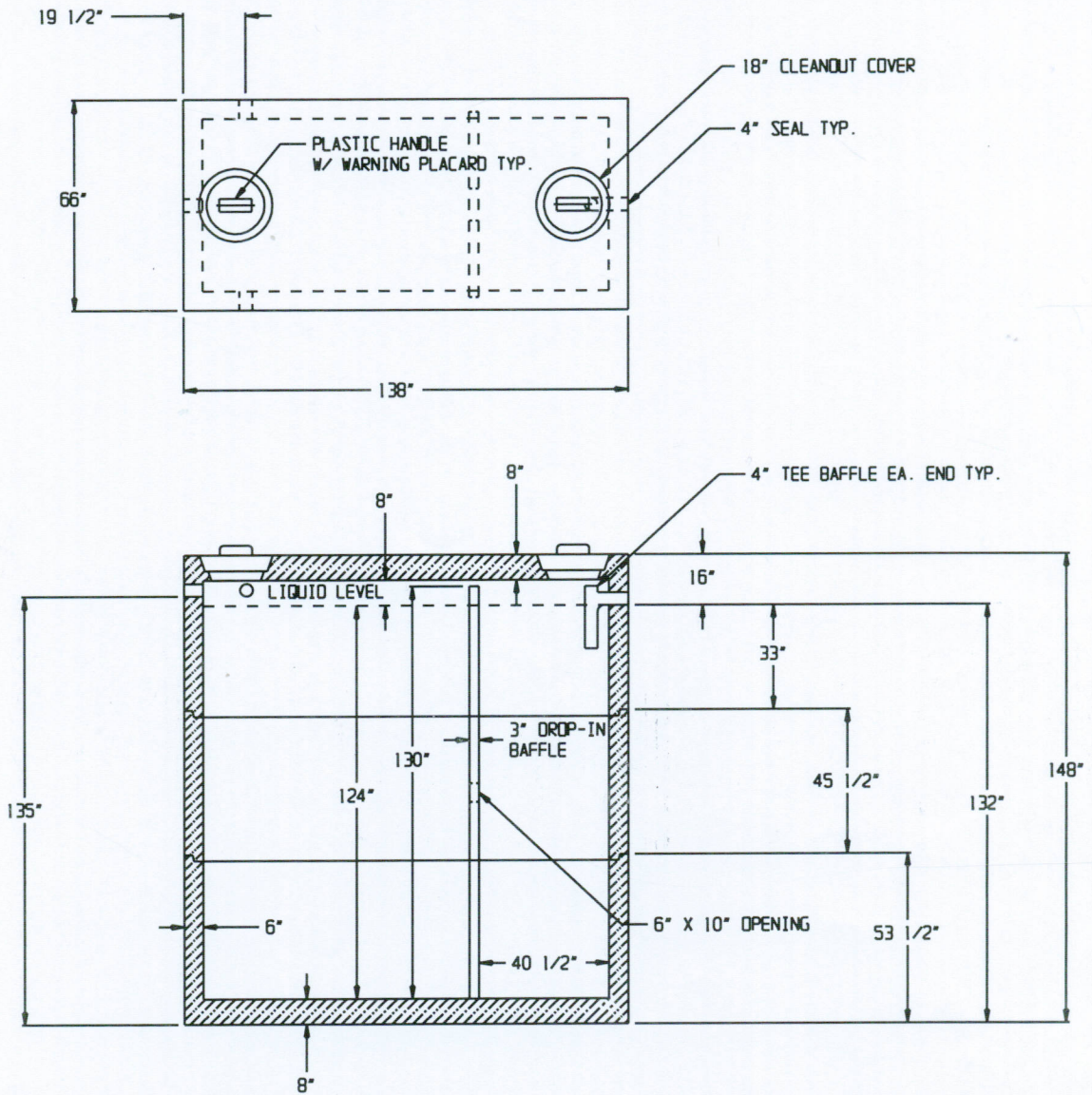

**SPECIFICATIONS:**

- \* Concrete Minimum Compressive Strength-5,000 P.S.I at 28 days.
- \* Materials & Manufacturing Per ASTM C-1227
- \* Steel Reinforcement:
  - Welded Deformed Bars 4"x 4" D6.5/D6.5 (Gr.80) ASTM A-497, or equal
- \* Joint Sealed w/1" Butyl Mastic ASTM C-990.
- \* 4" Diameter Outlet Tee Equipped w/Gas Deflector or Effluent Filter.  
Length Adjustment By Others If Required By Code.
- \* 4" Pipe Seals: Rissy Plastics Mini Boot, or equal. Meets Pressure Requirements of ASTM C-923.
- \* Capacity • Flow Line: 3,535 gallons
- \* 28.5 Gallons/ Inch of Rise
- \* Approximate Assembled Weight: Bottom= 14,300 lbs., Riser=8,800 lbs., Top=13,500 lbs.



2 COMMERCE DRIVE PO BOX 5133, BROOKFIELD, CT 06804  
 PHONE (203) 775-0230 FAX (203) 740-2059 WWW.EASTERNPRECAST.COM

PROJECT			
TITLE			
DRAWN BY BRETT B.		DATE 05-23-05	
DWG. NO.		SHEET	
3500H20ST		1 OF 1	
		REV. A	