

## 2A SUMP BASE/RISER

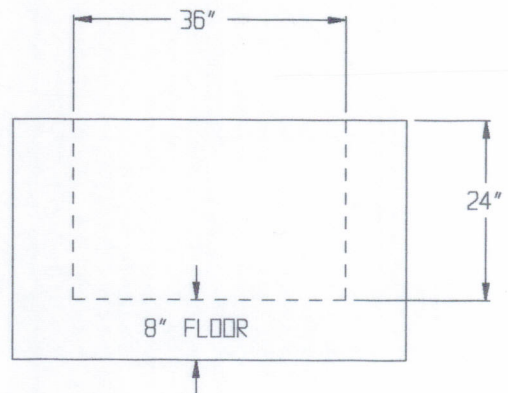
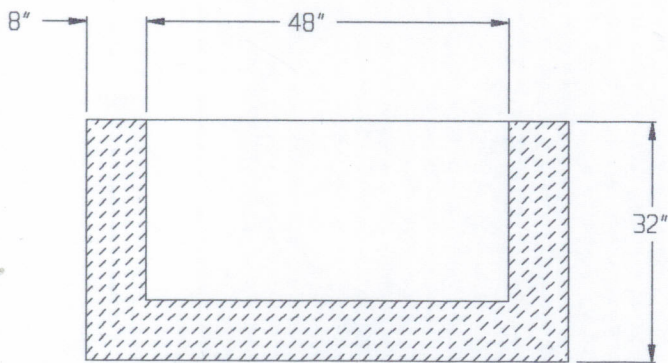
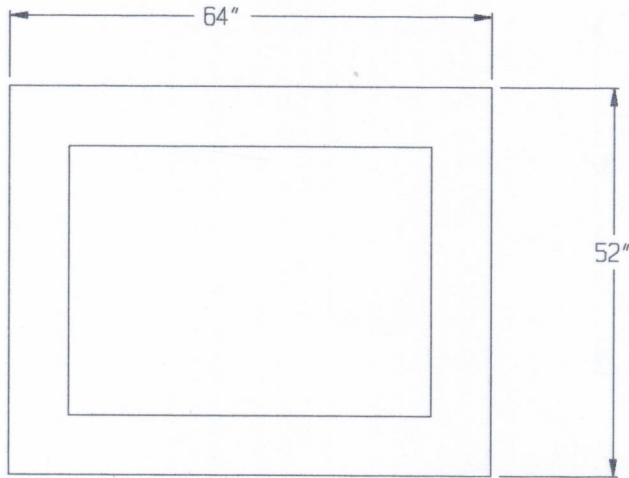

### SPECIFICATIONS:

- \* Concrete Minimum Strength-4,000 P.S.I at 28 days with Fibermesh.
- \* Steel Reinforcement: 6" x 6" x 10 Gauge Wire Mesh.
- \* Available Without 8" Floor To Make 24" Riser Section.

DWG # 2SBR5264

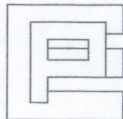

**EASTERN PRECAST CO. INC.**

P.O. Box 5133 2 Commerce Dr., Brookfield, CT 06804  
Phone (203) 775-0230 775-9380 Fax (203) 740-2059