

## Standard Transition Riser with Knockouts

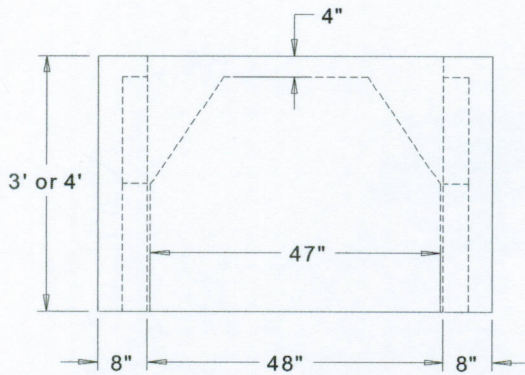

Thin wall knockout area for pipe entry. Penetration and mortar where needed by others.

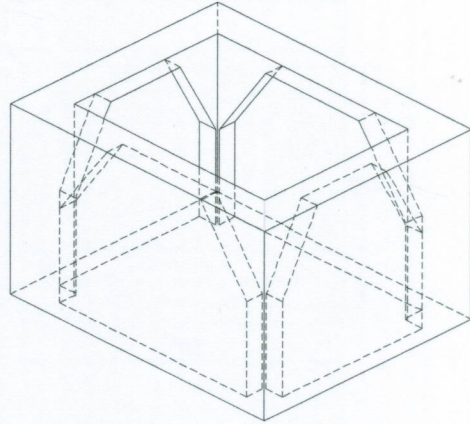
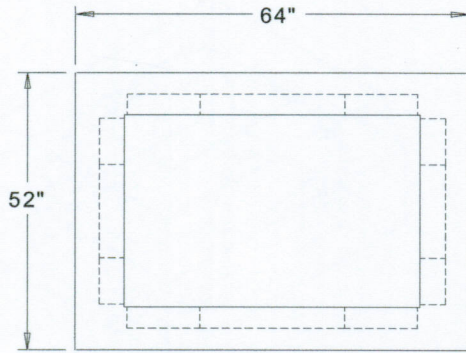
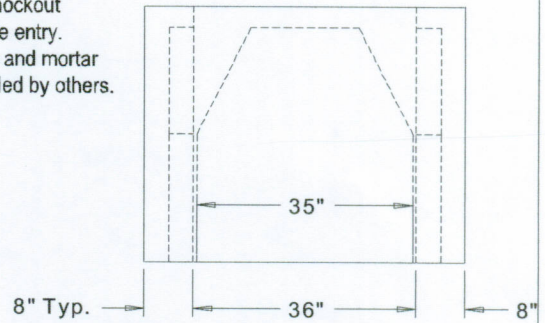

### Specifications.

- \*Concrete minimum strength: 4000 psi @ 28 days with fibermesh
- \*Steel Reinforcement: welded wire mesh 4" x 4" x w4/w4 (.12 sq. in. /VF)
- \*#3 Rebar Grade 40 over openings.
- \*Design load: H-20
- \*Approx. weight: 4' 3850 lb, 3' 3350 lbs.
- \*2 Recessed utility anchors on interior for lifting.

DWG # TRK34

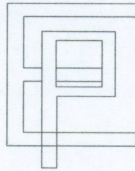

### EASTERN PRECAST CO. INC.

PO. BOX 5133, 2 COMMERCE DR.  
 BROOKFIELD CT 06804  
 Phone: (203) 775-0230, 775-9380  
 Fax: (203) 740-2059  
 WWW.eastemprecast.com