

STB-9 BAFFLE BOX (3 INLETS, 8 OUTLETS)

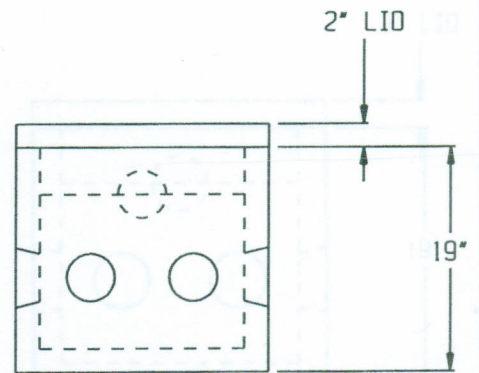

SPECIFICATIONS:

- * Concrete Minimum Compressive Strength-4,000 P.S.I at 28 days.
- * Steel Reinforcement:
 - Welded Wire Mesh 6"x 6"x W1.4/W1.4 ASTM A-185, or equal (Lid)
 - #3 Deformed Bar (Gr.40) ASTM A-615, or equal (Box)
- * Fibre Mesh Reinforcement ASTM C-1116: Euclid Tuf-Strand, or equal @ a Rate of 3.33 lbs/cy. (Box)
- * 4" Pipe Seals: Tuf-Tite TS-4Pro, or equal.
- * Approximate Weight: Box 420 lbs., Lid 180 lbs.

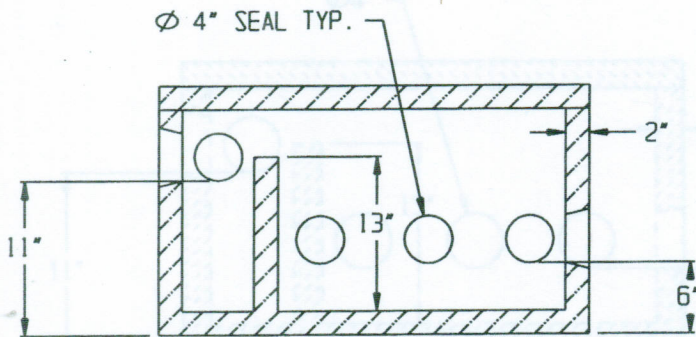
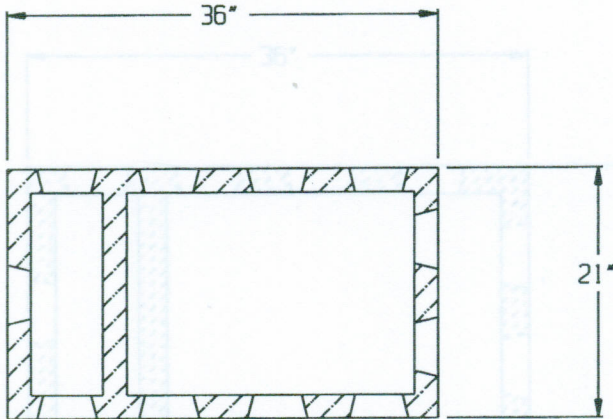

2 COMMERCE DRIVE PO BOX 5133, BROOKFIELD, CT 06804
 PHONE (203) 775-0230 FAX (203) 740-2059 WWW.EASTERNPRECAST.COM

PROJECT			
TITLE			
DRAWN BY Brett B.		DATE 09-19-05	
SCALE	DWG. NO.	SHEET	REV.
	STB9	1 OF 1	C