

48" X 48" SLAB

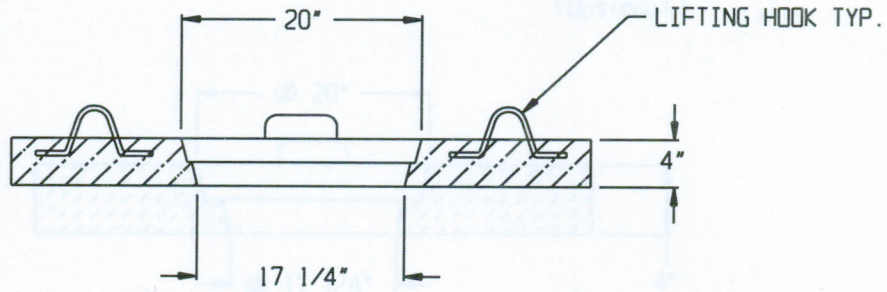

SPECIFICATIONS:

- * Concrete Minimum Compressive Strength-4,000 P.S.I at 28 days.
- * Steel Reinforcement:
 - Welded Wire Mesh 4" x 4" x W4/W4 ASTM A-185, or equal
 - # 3 Deformed Bar (Gr.40) ASTM A-615, or equal
- * Available Solid or With Inspection Cover.
- * Approximate Weight: 750 lbs.

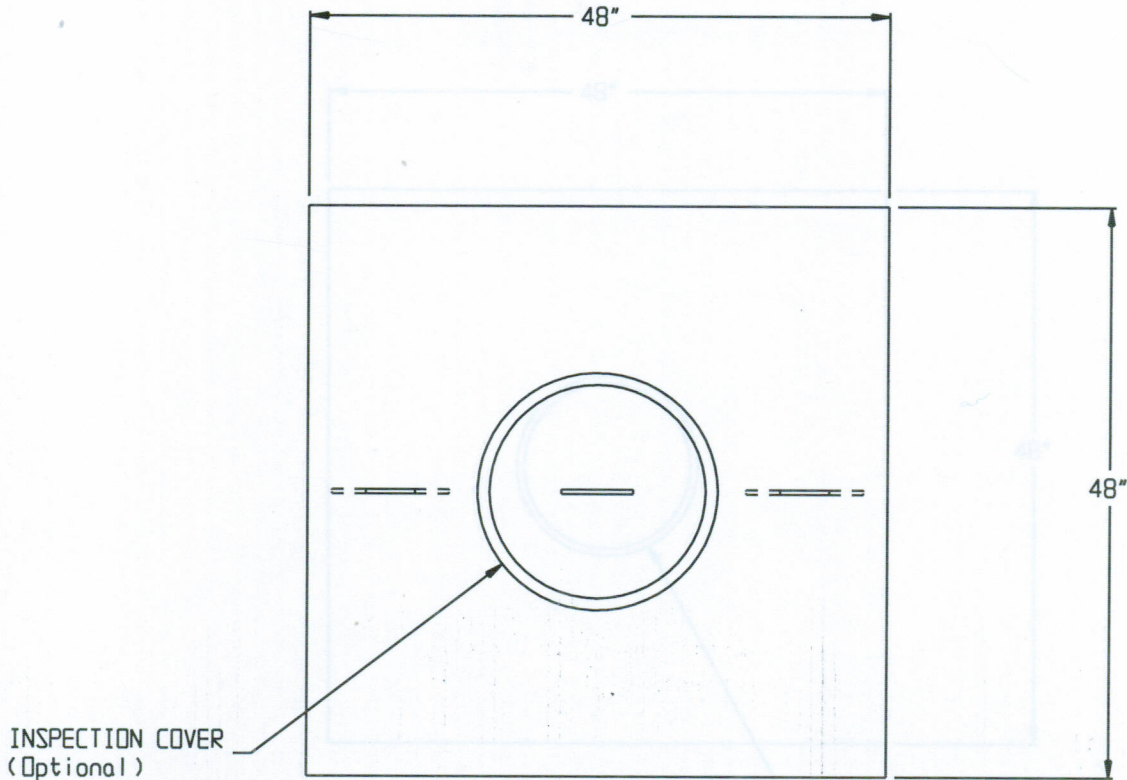

2 COMMERCE DRIVE PO BOX 5133, BROOKFIELD, CT 06804
 PHONE(203)775-0230 FAX(203)740-2059 WWW.EASTERNPRECAST.COM

PROJECT			
TITLE			
DRAWN BY BRETT B.		DATE 05-23-05	
SCALE	DWG. NO.	SHEET	REV.
	SLB4848	1 OF 1	C