

PRECAST DRY WELL, DW6

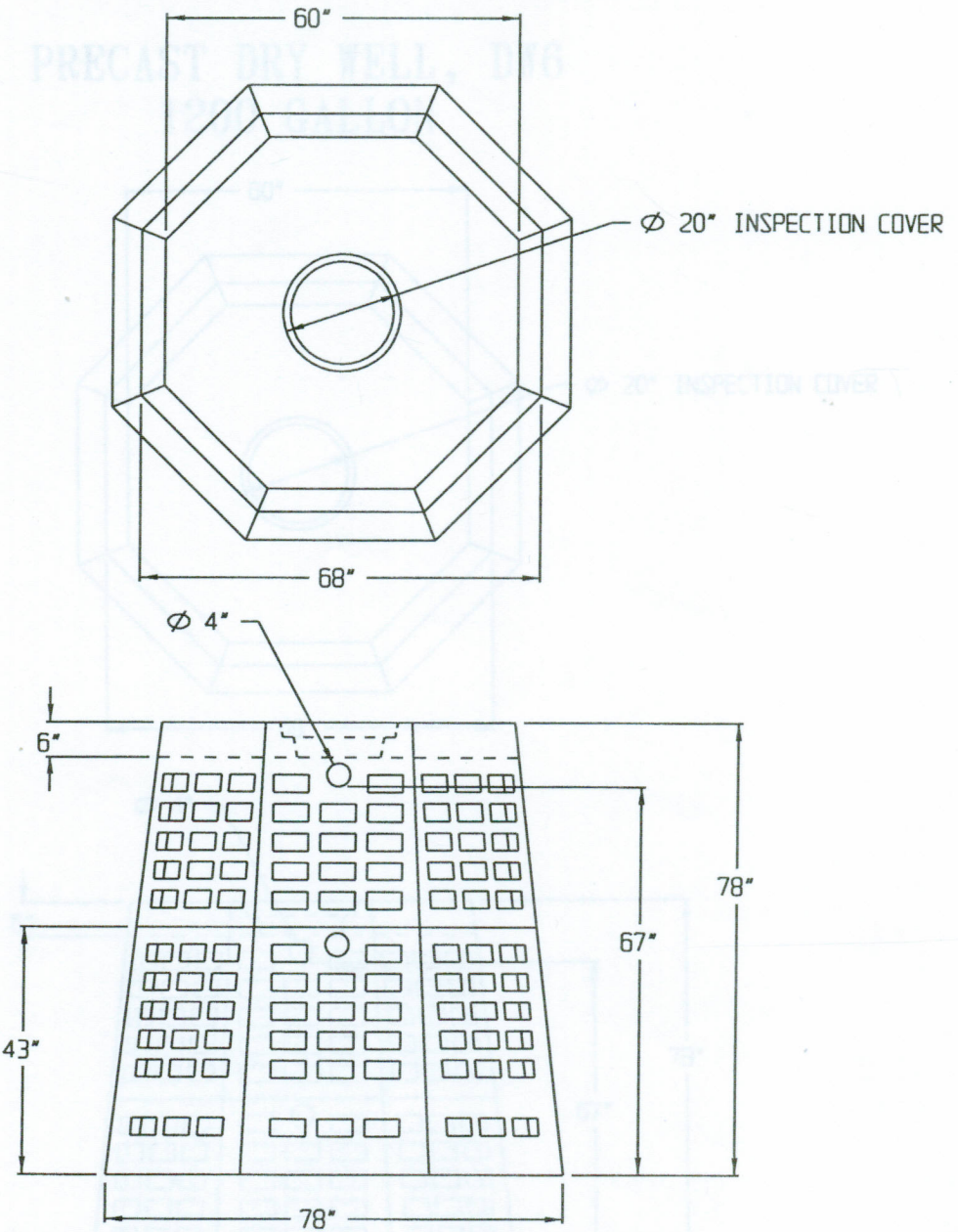

SPECIFICATIONS:

- * Concrete Minimum Compressive Strength-4,000 PSI @ 28 days.
- * Steel Reinforcement:
 Reg. Duty: #3 Deformed Bar (Gr. 40) ASTM A-615, or equal.
 H-20: #4 Deformed Bar (Gr. 60) ASTM A-615, or equal.
- * Fibre Mesh Reinforced ASTM C-1116: Euclid Tuf-Strand, or equal @ a Rate of 3.33 lbs/cy.
- * Capacity: 1,200 gallons
- * Approximate Weight: Top 2,600 lbs., Bottom 2,500 lbs.



2 COMMERCE DRIVE PO BOX 5133, BROOKFIELD, CT 06804
 PHONE: 203 775-0230 FAX: 203 740-2059 WWW.EASTERNPRECAST.COM

PROJECT			
TITLE			
DRAWN BY Brett B.		DATE 5-01-05	
SCALE	DWG. NO.	SHEET	REV.
	DW6	1 OF 1	B