

DB-4 2" HIGH OVERFLOW

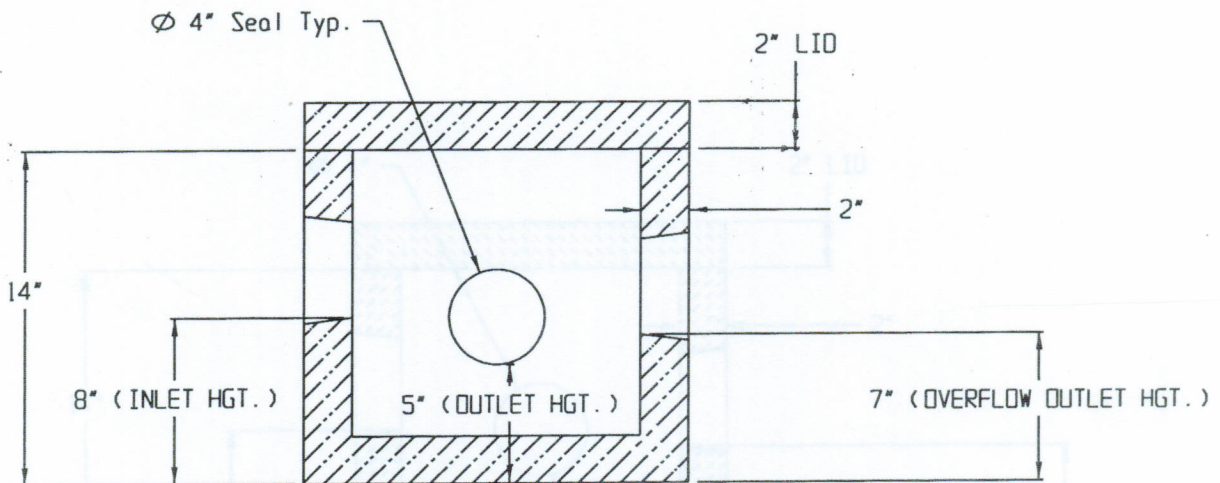

SPECIFICATIONS:

- * Concrete Minimum Compressive Strength-4,000 P.S.I at 28 days.
- * Steel Reinforcement:
Welded Wire Mesh 6"x 6"x W1.4/W1.4 ASTM A-185, or equal (Lid)
- * Fibre Mesh Reinforcement ASTM C-1116: Euclid Tuf-Strand, or equal @ a Rate of 3.33 lbs/cy. (Box)
- * 4" Pipe Seal: Tuf-Tite TS-4Pro, or Equal.
- * Available With Cast Iron or Steel Grate for Yard Drain.
- * Approximate Weight: Box 135 lbs., Lid 40 lbs.

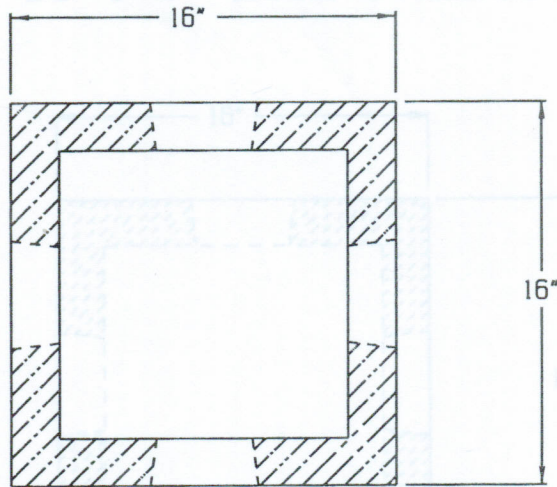

2 COMMERCE DRIVE PO BOX 5133, BROOKFIELD, CT 06804
 PHONE (203) 775-0230 FAX (203) 740-2059 WWW.EASTERNPRECAST.COM

PROJECT			
TITLE			
DRAWN BY	BRETT B.	DATE	05-23-05
SCALE	4:1	ONG. NO.	DB402
SHEET	1 OF 1	REV.	B