

PLAN

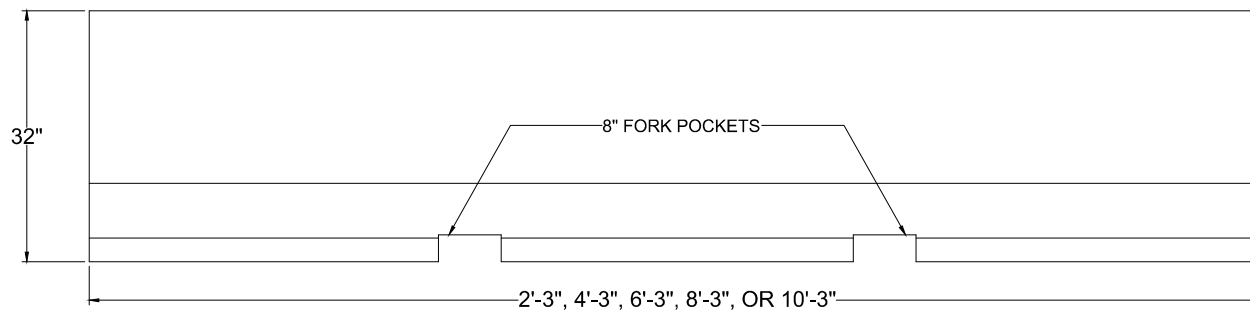

ELEVATION

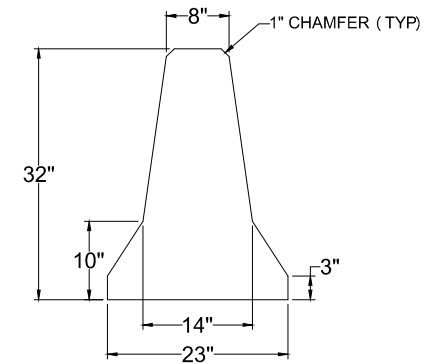

SIDE VIEW

Specifications :

- Concrete Minimum Compressive Strength - 4,000 psi @ 28 days
- Concrete Air Entrainment : 4% - 9%
- Type I, or Type I/II Cement
- Steel Reinforcement :
#4 Deformed Bar (Gr.60) ASTM A-615, or equal
- Fiber Mesh Reinforcement ASTM C-1116 @ a Rate of 4.0 lbs/cy
- Approximate Weight: 400 LBS/LF
- Cast-in Utility Anchors Where Needed, for Handling

NOTES :

MATERIAL :

DOCUMENT APPROVED BY : DATE :

DWNG DATE : 02/16/2019

CHKD DATE :

TOLERANCE

MODEL NO.

LOAD RATING

N/A

REVISION 1 - DATE

REV

REVISION 2 - DATE



EASTERN PRECAST
COMPANY, INCORPORATED

2 COMMERCE DRIVE, BROOKFIELD, CT 06804
PHONE : (203) 775 - 0230 FAX : (203) 740 - 2059
WWW.EASTERNPRECAST.COM

DOUBLE FACE MEDIAN BARRIER